

Non-invasive ventilation (NIV) at home

Information for patients using a Nippy 4 or Nippy 4+ ventilator

This leaflet provides information for patients using a Nippy 4 or Nippy 4+ ventilator. If you have any other questions or concerns, please do not hesitate to speak to the team caring for you.



What is non-invasive ventilation?

Non-invasive ventilation (NIV) is a treatment that can help you breathe more easily if your breathing problem is getting worse. NIV supports your breathing but does not take over it. It involves you using a cushioned mask that fits over your mouth and nose (Fig 1), or just your nose (Fig 2).



Fig 1. Full face mask



Fig 2. Nasal (nose) mask

Why do I need NIV?

When you breathe normally you take in oxygen for your body to use and breathe out the waste gas carbon dioxide. Breathing in enough oxygen and blowing out enough carbon dioxide might have become more difficult for you. NIV helps your breathing by blowing in extra air as you breathe. This helps correct your oxygen and carbon dioxide levels.

What are the benefits of NIV?

NIV improves the effectiveness of your breathing and can reduce the work of breathing for your muscles, which can make breathing easier for you. Other benefits may include improved sleep quality, reduced sleepiness in the day and less frequent morning headaches.

While wearing the mask, you can sleep or be awake to co-operate with chest physiotherapy. You are also able to talk, and the mask can be removed easily for eating and drinking.

What are the side effects of NIV?

- The face mask may make you feel claustrophobic.
- Air may leak from around the mask and cause eye discomfort.
- If you swallow some of the air it can lead to trapped wind or bloating. If this happens, the settings on your machine may need to be changed.
- Nose, mouth or throat dryness. If this happens, we can give you a humidifier to help.
- The mask may cause sore skin on your face or make your skin break down over the bridge of your nose. If you find this is a problem, you may need to try different masks or use extra liners to create a comfortable fit.
- You may find it harder to clear spit and phlegm from your throat and nose when you wear the mask. You may need to remove the mask for a few minutes to spit it out.

What are the risks of NIV?

Pneumothorax (lung collapse). This is very rare and only if the machine is set at high pressures. It is caused by an air leak from the lung which becomes trapped between your lung and chest wall. It may cause sudden sharp chest pain, which is worse when you breathe in, and breathlessness. You will need to attend your local A&E urgently if this happens.

How often should I use the NIV machine?

It is important to use your NIV every night, for a minimum of 4 hours (ideally the whole night if you can). You should also use your NIV if you sleep in the daytime. Your doctor will tell you if you need to use your NIV any more than when you are asleep. If you are having any doubts about how often you should use your NIV, you can contact the Chest Unit or your doctor.

Do I still need to take my normal medication while using NIV?

Yes. You should take all your usual medicines unless advised otherwise by your doctor. You can take the mask off if you need to take your nebulisers, inhalers or pills.

Will I have follow-up appointments for my NIV?

You will be seen regularly in the Chest Unit to ensure your treatment is going well. You also may be seen regularly in the Sleep and Ventilation Clinic. It is important that you attend all your appointments to check that your NIV therapy is effective and to discuss any problems you may be having. If you do not attend for your appointments, the Home Ventilation Team will not be able to accept responsibility for the safety of the NIV machine or your treatment.

Remote monitoring

Some of our devices may be fitted with a device called a modem that can send us information about the effectiveness of your NIV treatment. It can also tell us how often you are using it and if your mask is fitting properly. This will enable us to optimise your treatment while reducing your number of hospital visits. The modem sends your data securely. It does not use your internet connection and so will not cost you anything when it sends us the information. We will always ask your permission first before fitting the modem.

Traveling with NIV

Nippy 4 machines are considered FAA compliant and may be used on board an aircraft, without further testing by the carrier.

Some airlines may require advance notification before travel, and devices may need to be operated by battery. We recommend that you check with the airline prior to traveling.

Please take the machine on to the plane as hand luggage, to avoid accidental damage. Do not check the NIV ventilator into the plane cargo or hold.

If you are going abroad, please contact the Chest Unit so that we can supply you with a letter for the airline and customs.

Using my Nippy machine

How do I turn it on and off?

Place the Nippy machine on a clean flat surface (not on a carpet). Do not put it inside a bedside cabinet or anywhere where the air cannot move freely around it. Never cover the Nippy machine.

- Connect the power lead to the adapter and then the adapter connector to the back of the machine.

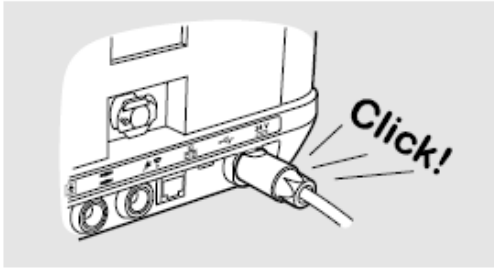

- Plug the other end of the lead into the mains power socket and switch the socket on.
- Connect your tubing to the air outlet.

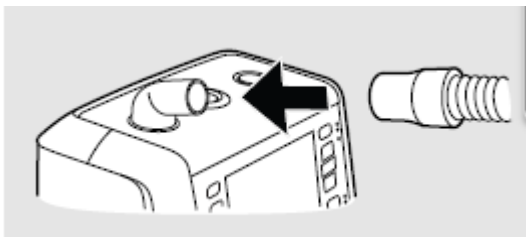

- To switch the Nippy on, press the power on/off button on top of the Nippy. The Nippy will sound and the screen should light up. This will take about 15 seconds.

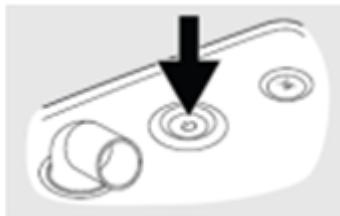

- A message 'Pre-use Test - waiting for system initialisation to complete' will appear followed by the message 'Perform pre-use test'.
- Select NO by pressing the bottom right button.

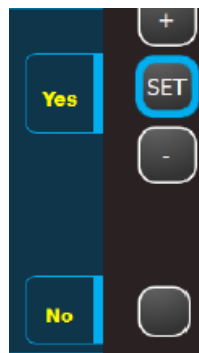

To stop or start treatment

- To start the flow of air press and hold the power on/off button until the progress bar is filled.

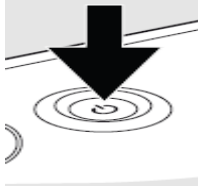

- To stop the flow of air press and hold the power on/off button until the progress bar is filled and then select YES by pressing SET to confirm you wish to stop treatment.

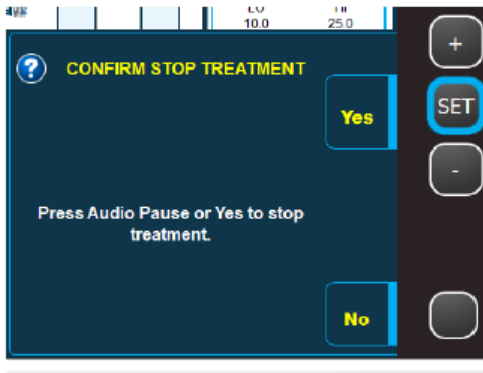

- If you want to turn the power off completely press the power on/off button quickly (do not hold down) and select OFF by pressing the SET button.

Will I need to use oxygen with my NIV?

Some patients will need additional oxygen therapy alongside the NIV treatment at night. If you are deemed in need of oxygen, our Home Oxygen Team will arrange for an oxygen concentrator machine to be delivered to your home.

We will show you how to connect oxygen to your NIV machine before you leave hospital. One end of the oxygen tubing should be attached to a connector piece that we will provide you (see below), and the other end should be attached to your oxygen concentrator.

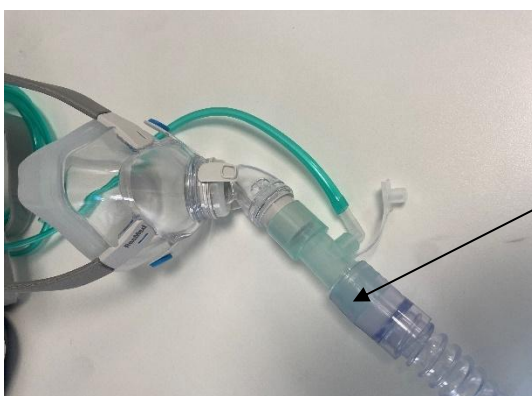

Oxygen connector with tubing

Your oxygen concentrator should be set at litres per minute when connected to your NIV machine.

Will I need a humidifier as well?

We might decide that breathing damp (humidified) air will help you if you have a productive sticky cough (you cough up phlegm or mucus) or a dry mouth or throat.

The humidifier is a clear chamber that is inserted into the side of the side of the machine.

Note: If the ventilator is equipped with a click-in battery or an airway bypass unit these should be removed before installing the water chamber.

Humidification chamber

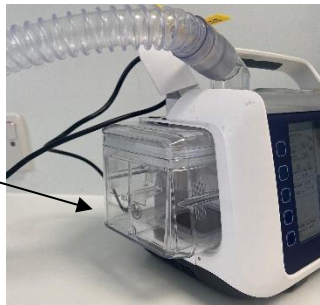

Lift the handle and push these two buttons down and pull the chamber to remove.

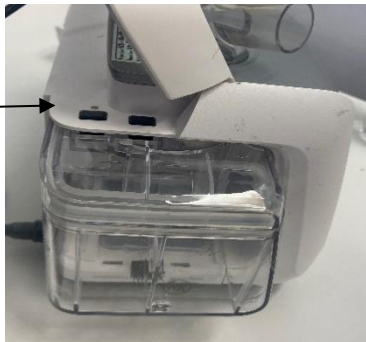

Fill it no higher than the maximum fill line with water (cool boiled or distilled water).

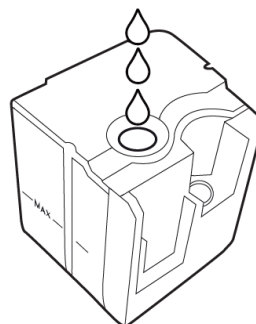

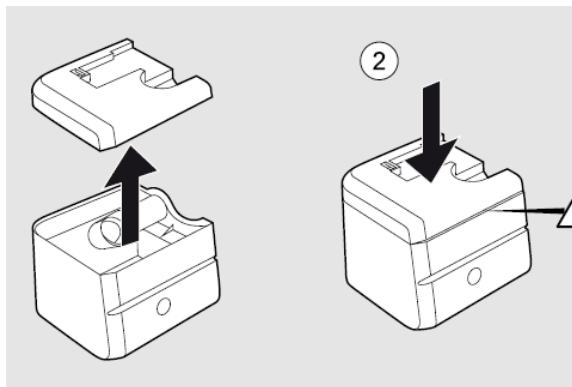

You can also remove the lid and fill the water through the top of the chamber. Always make sure the lid of the water chamber is totally sealed before re-inserting.

Re-insert the chamber and push it until you hear an audible click.

Warning

To avoid a burn injury, be careful not to touch the heater plate or the heated water in the water chamber when the humidifier is switched on or has not yet cooled down. Wait 10 minutes for the heater plate and water to cool.

Always stop treatment before detaching or attaching the water chamber.

Never add or pour out water from the water chamber when it is attached to the ventilator.

Caution

- Use only distilled or sterilised water or boiled, chilled tap water in the humidifier water chamber. This is to reduce mineral deposits and maximise the life of the water chamber.
- Do not fill the water chamber with hot water.
- Do not overfill the water chamber. Fill only to the maximum level indicated on the water chamber.
- Always ensure the lid with seal is properly mounted after filling and reassembling the water chamber.
- Also check that the water chamber is correctly docked in place and locked to the ventilator.
- Make sure all parts are dry before the ventilator is connected to the mains and put into operation.
- Change the water in your humidifier every day to prevent mould and bacteria growth. Any remaining water in the morning should be disposed of.
- Do not put any chemicals or additives into the water as these may irritate your airway or damage the water tank.
- Do not attend your NIV review appointments with water in the humidifier chamber as this will damage your machine.
- If you are getting a lot of moisture or water inside your mask and tubing, the humidifier is set too high. Adjust your humidification settings.

Adjusting the humidification level

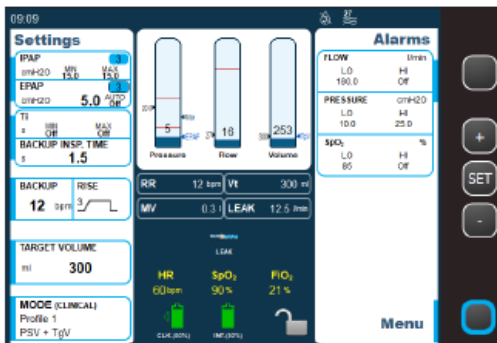

Press the menu button

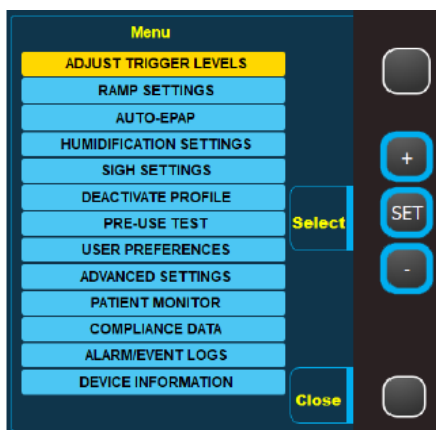

Use the + and - buttons to highlight humidification settings and press the SET button to open it.

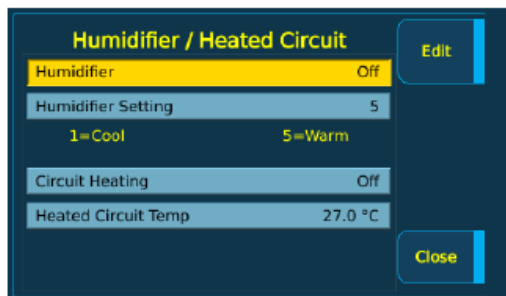

Use the + and - buttons to highlight humidifier settings and select EDIT.
Use the + and - to change the settings and then CLOSE to save.

Please note your humidifier will not work and you will not be able to adjust the settings if you are using the internal battery. It must be plugged into the mains.

Internal battery

All Nippy 4s have an internal battery. The internal battery is intended as a backup power source if the primary power source fails. If this happens the ventilator will alarm and will switch to the internal battery. A message will be displayed on the screen to make you aware that the battery is being used.

The internal battery will last approximately 2.5 hours depending on your settings.

'Click in' battery

You may also be provided with a click-in battery. The click-in battery is intended as a power source during transportation, or if the primary mains power source fails. The click-in battery can be replaced during treatment, provided that the internal battery is charged.

The click in battery will last approximately 3 hours depending on your settings.

Release the side cover by pressing the button under the handle.

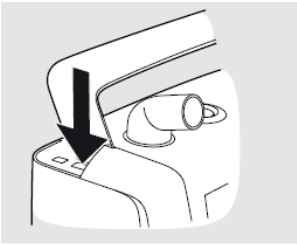

Remove the side panel

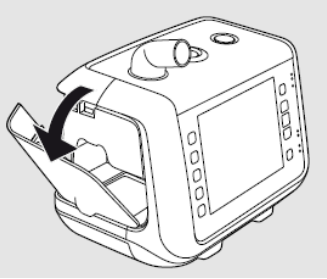



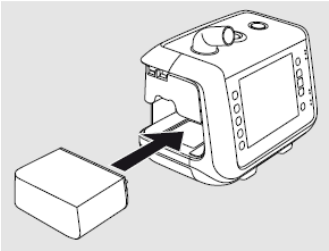

Insert the 'click in' battery and replace the side cover. Make sure its clicks into place



When running on the battery the battery status is indicated by the following symbols.

When the Nippy machine is on standby, it will display a battery percentage in brackets below the battery icon. However, once you put the device in therapy, after a couple of minutes, the percentage will change to hour and minutes remaining, based on the settings.

Symbol	Description
	Internal battery Green symbol indicates over 50 % state of charge.
	Click-in battery Green symbol indicates over 50 % state of charge.
	Medium State of charge (20 % – 50 %)
	Low state of charge (below 20 %)
	Malfunctioning battery

Looking after my NIV machine

Machine care

Keep the NIV machine clean and dust free.

If you are using a humidifier:

- you can wash the water chamber in warm soapy water or in the top drawer of a dishwasher
- if you get a build-up of lime scale/mineral deposits, you can fill the chamber with lemon juice and warm (pre-boiled) water and leave to soak for three to four hours or fill with citric acid and warm water and leave for 30 minutes – make sure that the solution is rinsed off thoroughly before re-using

One of the Chest Unit Team can show you how to clean the different parts of your machine and give you any new or replacement parts you may need.

Mask care

Before putting on your mask, always wash your face to remove facial oils and make-up. Do not put moisturiser on your face at night as this may stop the mask from sealing.

If you look after your mask it should last a year. If it breaks or starts to leak a lot, contact the Chest Unit for a new one.

Daily

- Take the mask cushion or nose pillows off the straps. Clean with warm soapy water, rinse and leave to dry.
- Do not use alcohol on the mask as this can damage it.
- Do not put it in the dishwasher or very hot water.

Weekly

- Take off the straps, wash in warm soapy water and leave to dry.

Tubing care

Clean the tubing before you first use it.

Weekly

- Detach the flexible tubing from the NIV machine.
- Gently wash the tubing with warm water and a mild detergent.
- Rinse well.
- Hang it over a chair or the back of a door to drip dry.
- Check the tubing regularly for holes. These can cause a high flow alarm to sound.

Filter care

The patient air filter is located at the side of the machine and prevents dust from entering.

Disconnect the device from the power source and place on a dust free surface.

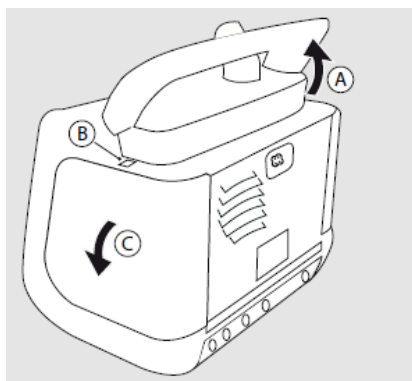

Lift the handle (A) to access the release button.

To remove the filter side panel, press and hold the button above the panel (B).

Remove the panel (C).

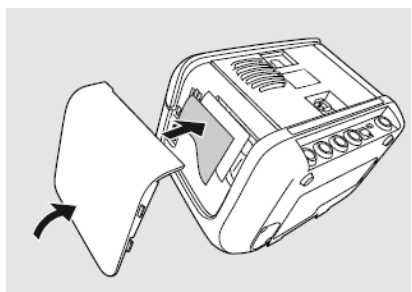

Remove and wash (or replace) the filter.

Make sure the filter is completely dry before replacing it and closing the side panel.

The cooling air inlet filter is located at the bottom left side of the ventilator.

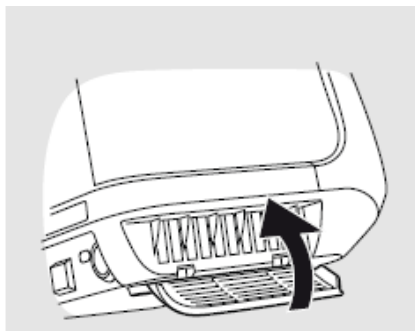

Remove by pulling the filter cover downwards and take out the filter. Wash or replace the filter.

Make sure the filter is completely dry before replacing it and closing the filter cover.

Weekly

- Remove both the patient air filter and the cooling air inlet filter.
- Remove any visible dust.
- Wash the filters using warm water and mild soap.
- Rinse thoroughly.
- Dry the filters by squeezing them out on a towel – do not wring.
- Make sure the filters are completely dry before reinserting.

Yearly

Replace both filters.

Caution: Never install a wet filter into the device. You must ensure sufficient drying time for the cleaned filter.

Important: Do not let the filter get blocked with dust because this will affect how well the ventilator works.

What do I do if I have problems with my mask?

Generally, it is ok to have small leaks. You can make some small changes to stop big leaks.

- If your mask leaks, pull the mask cushion directly away from your face and set it gently back into place. This allows the cushion to create a new seal on your face.
- If you have leaks around your eyes, adjust the side straps.
- If you have leaks around your lips or chin, adjust the lower straps.
- If you can feel too much pressure on the bridge of your nose, loosen the side straps.
- If you get a sore on the bridge of your nose, please contact the Chest Unit for advice.

What to do if the alarm sounds?

The alarm may sound for a few reasons. A message will be displayed on the screen telling you the type of alarm. To temporarily silence an alarm, press the alarm silence button.



The alarm is silenced for 60 seconds and then sounds again if the cause of the alarm has not been corrected.

The NIV machine can alarm for different reasons:

HIGH FLOW indication on the screen. There may be leak around the mask, the tubing may be disconnected or there may be a hole in the tubing.

In this case, try refitting your mask and making sure it is securely fitted, check all tubing is connected and check for holes in the circuit (tubing can be replaced). A high flow alarm may also sound if you are coughing.

LOW FLOW. There may be a blockage in the tubing (check for water in the tubing if you have a humidifier) or you may have fallen asleep and your head dropped forwards and you are obstructing the airflow.

In this case, check that nothing is blocking the tube. Try tilting your head position back to allow the air to flow freely or if your mouth is open and you wear a nasal (nose) mask, make sure you are wearing your chin strap.

HIGH PRESSURE. May be due to coughing.

LOW PRESSURE. There may be leak around the mask, the tubing may be disconnected or there may be a crack in the tubing.

DISCONNECTION. There may be a leak around the mask, the tubing may be disconnected or there may be a crack in the tubing. If you remove the mask and do not turn off the flow within 15 seconds this alarm will sound.

REBREATHING. There may be a blockage in the tubing (check for water in the tubing if you have a humidifier).

Make sure you are using a mask that has the exhalation ports in it and that these have not become blocked.

LOST MAINS FAILURE. Occurs when the ventilator switched from mains to either the internal or click in battery due to mains power being lost.

If you have checked for the above and you are worried that the alarm is still sounding, please contact the Chest Unit with your query.

Who can I contact with queries and concerns?

Before you go home, someone from the NIV team or Chest Unit will show you how to fit your mask and how to use your Nippy device.

If you have any problems with your machine at home, please contact the Respiratory Physiologists.

Chest Unit King's College Hospital

Tel: 020 3299 4743, option 3

Email: kch-tr.CPAPkings@nhs.net

Chest Unit Princess Royal University Hospital (PRUH).

Tel: 01689 863104

Your Nippy NIV settings

Machine model -----

Serial number -----

IPAP (cmH2O) -----

EPAP (cmH2O) -----

Ti (secs) -----

Back up rate (bpm) -----

Mode -----

Rise time -----

Mask -----

Oxygen rate (L/min) -----

MyChart

Our MyChart app and website lets you securely access parts of your health record with us, giving you more control over your care. To sign up or for help, call us on **020 3299 4618** or email **kings.mychart@nhs.net**. To find out more visit **www.kch.nhs.uk/mychart**.

PALS

The Patient Advice and Liaison Service (PALS) is a service that offers support, information and assistance to patients, relatives and visitors. They can also provide help and advice if you have a concern or complaint that staff have not been able to resolve for you. They can also pass on praise or thanks to our teams.

Tel: **020 3299 4618**

Email: **kings.pals@nhs.net**

If you would like the information in this leaflet in a different language or format, please contact our Interpreting and Accessible Communication Support on 020 3299 4618 or email **kings.access@nhs.net**